

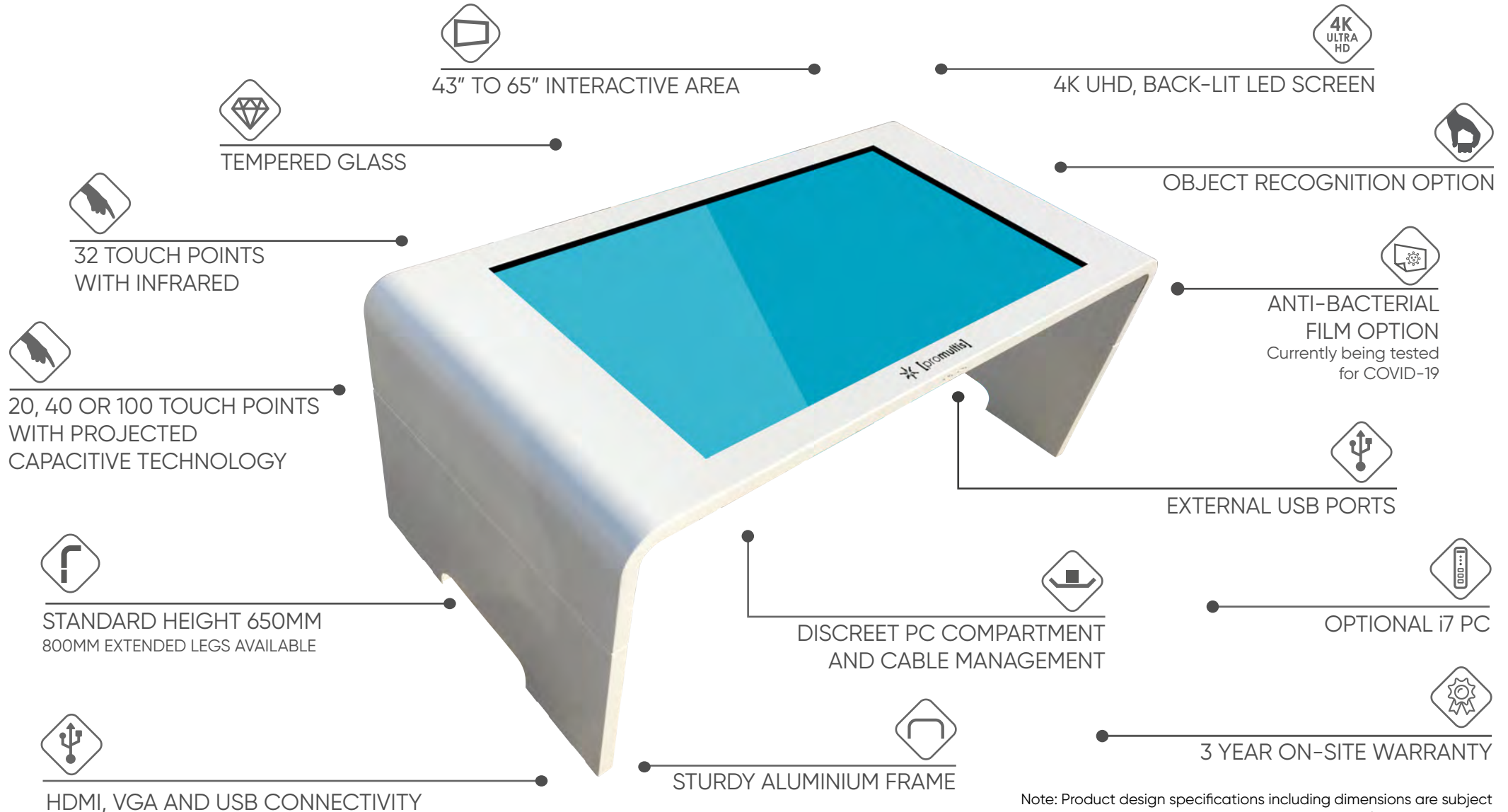

[promultis]

# Touch Table

The Promultis Table is a complete multi-touch, collaborative interactive surface solution that integrates the latest touch screen technology into a table.



Note: Product design specifications including dimensions are subject to change without notice and may vary from those shown.

**The Promultis Table is a slim, stylish and futuristic piece of hardware. Constructed from sturdy aluminium in a coffee table design, the Promultis Table is a collaborative, interactive multitouch surface solution that integrates the latest touch screen technology into a user-friendly and intuitive design.**

The Promultis Table is available in a variety of configurations; Interactive areas from 42" up to 65", with 4K UHD LED screens, optional integrated PC and a choice of software bundles.

There is also the option of infra-red or Projected Capacitive touch technology with up to 32 touch points and custom leg height options that make the table optimal for wheel chair users.

Promultis touch tables are ideal for:

- Receptions
- Foyer Areas
- Waiting Rooms
- Dining Halls
- Exhibition Stands
- Libraries



### Secure PC and cable housing

Should an integrated PC be specified, there is a secure PC housing beneath the table along with integrated cable management.

### Integrated USB connections

Includes 4 USB ports accessible from the sides of the table.

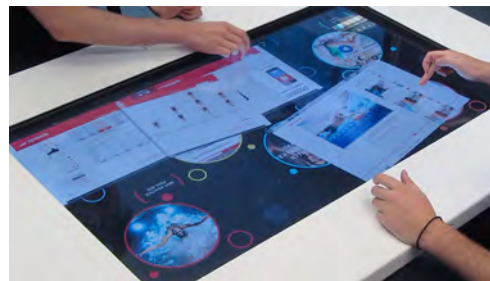

### Immerse Bespoke Interactive Software from Promultis

Promultis offers a bespoke software creation service where our software development team will create a multitouch interactive experience to run on your touch table. Visit our website at <https://immerse.promultis.info/> for example applications and case studies.

### Colour and applied graphics

Select a bespoke colour for your table or apply vinyl graphics with your corporate identity and marketing messages.



### Interactive surface area

The table provides a large working surface area allowing several users to collaborate all at the same time. Users can control the content they see by using natural gestures such as pinch, zoom and drag.



### Software options

The Snowflake Suite Ultimate is perfect for education and training, its fully featured with all over 52 apps, including presentation, creativity and productivity tools, as well as games. It is intuitive and easy to use and customisable to suit your needs.



### Object Recognition Ready

Object recognition is the ability to drop an interactive puck onto the screen and the screen to react to that object and display relevant content such as videos, pictures and graphics. Promultis offers an object recognition software service detailed on the Immerse website.

CHASSIS FEATURES	
Materials	Aluminium
Glass type	Toughened
Tray	Cable Management and PC shelf
Base	4 Floor Levelling Castors
PANEL	
Interactive area	42"   49"   55"   65"
Panel resolution	4K UHD 3840 x 2160
Native resolution	3840 x 2160 60Hz
Brightness (nits)	450
Contrast ratio	1500 to 1
Response time	6ms
Aspect ratio	16x9
Viewing angle	178° / 178°
Pixel pitch	0.744 (mm)
LCD Illumination	Backlit LED
Speaker	10W x2
ENVIRONMENT	
Operating temperature	50°F to 104°F (10°C to 40°C)
Operating Humidity	10% to 80%, non-condensing
Storage Temperature	-4°F to 113°F (-20°C to 45°C)
Storage Humidity	5% to 95%, non-condensing
SHIPPED WITH	
Cables	Power   USB   HDMI
Remote control	Included
User manual	Included
WARRANTY	
3 year on-site warranty as standard	
Extended warranties and SLA's available at an additional cost	

INFRA RED TOUCH	
Touch Points	32
Touch sensitive to	Finger, Opaque object, Stylus
Sunlight Sensitivity	Can be used in direct sunlight
Interpolation	32,768x32,768
Response time	Repeated touch <6ms
Drift	None
Temperature	-20°C~60°C
Accuracy	±2mm
Interface	USB-2
Relative Humidity	10%~90%RH
Supported	OS Windows, MAC, Linux, Android
PROJECTED CAPACITIVE	
Detection method	Projected Capacitive
Input method	Finger and gloved finger
Number of simultaneous touches	20, 40 or 100
Noise Shielding	DISPLAX XTR-Shield™ Plus, a proprietary noise filtering technology
Aspect ratio	16:9
Controller	Printed circuit board with mini USB connector
Adhesive	Permanent
Interface	HID
OS with multitouch	Windows 8.1, 8, 7, 10; Ubuntu 12.04; Android; Chrome OS
OS with single touch	Mac OS X Yosemite
OS with mouse emulation	Spinetix Media Player HMP 200
Data connectivity	USB 2.0
Touch accuracy	1mm absolute

PERFORMANCE			
Substrate thickness	Up to 6mm		
Touch response	5 milliseconds		
Calibration	Available using control panel: no drift		
POWER CONSUMPTION			
Average power consumption (P)	USB powered @ 5V		
	Peak consumption: 410 mA		
	Operation consumption: 370mA		
RELIABILITY			
Operating temperature range	-20°C to 70°C		
Operating humidity range	0% to 96%		
Life time expectancy	Unlimited		
Controller life time expectancy	1 million hours		
TABLE DIMENSIONS			
	Width	Depth	Height
42"	800 mm	1600 mm	650 mm*
49"	800 mm	1600 mm	650 mm*
55"	1000 mm	2000 mm	650 mm*
65"	1000 mm	2000 mm	650 mm*



\*800mm taller leg option available at additional cost



[promultis]

# 42" & 49" Touch Table

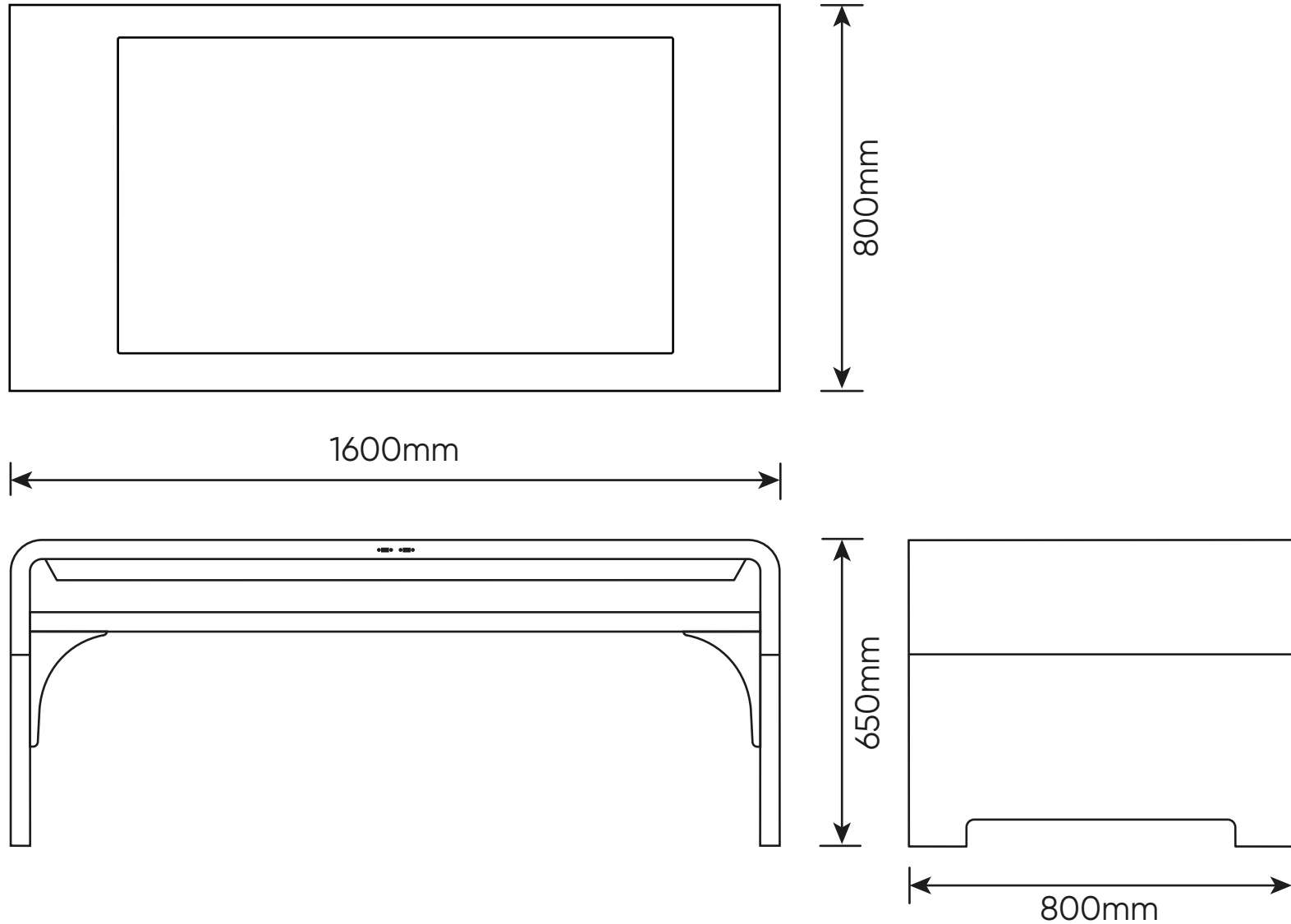



[promultis]

# 55" & 65" Touch Table

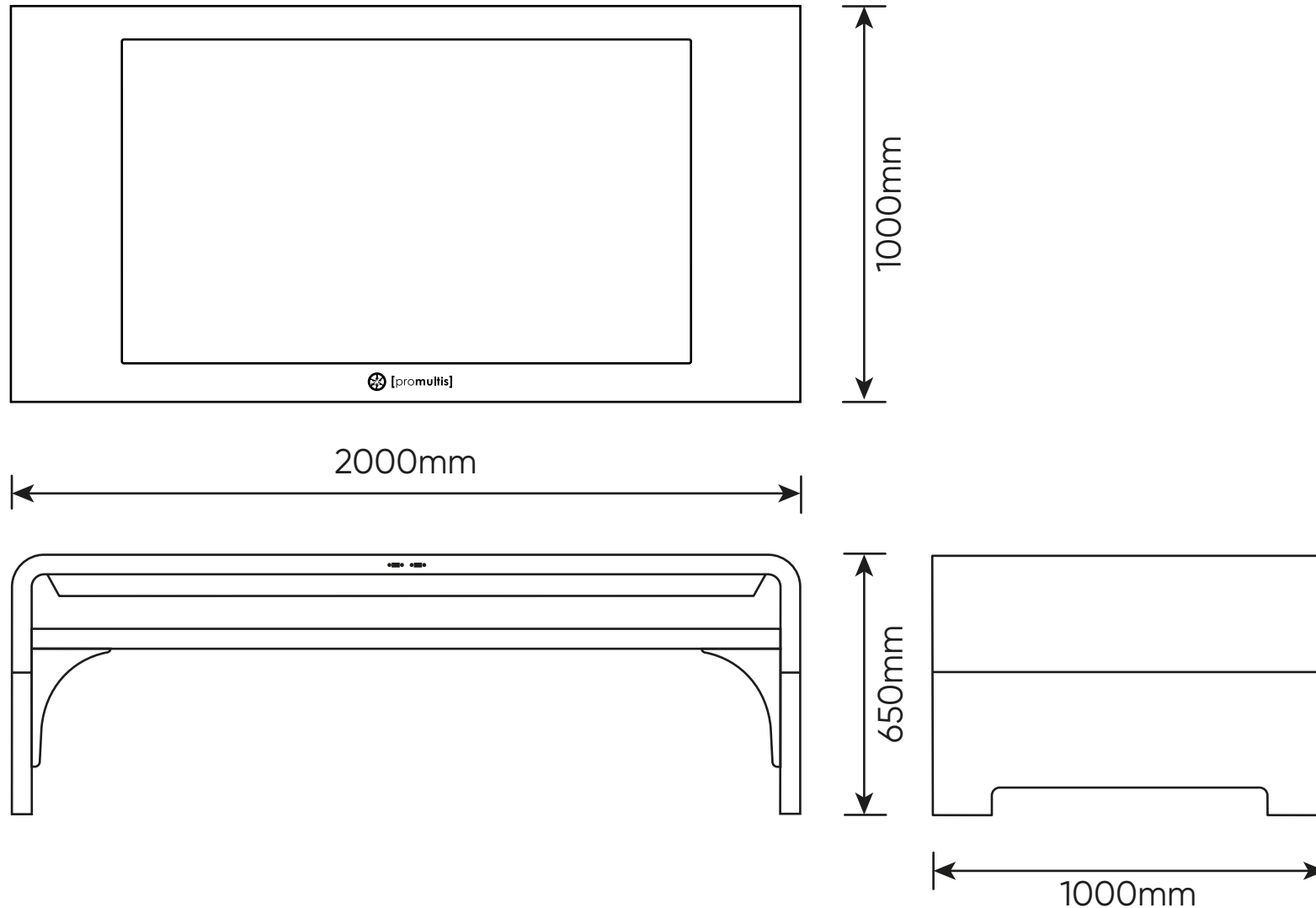



[promultis]

# 65" Touch Table with Extended Legs

