

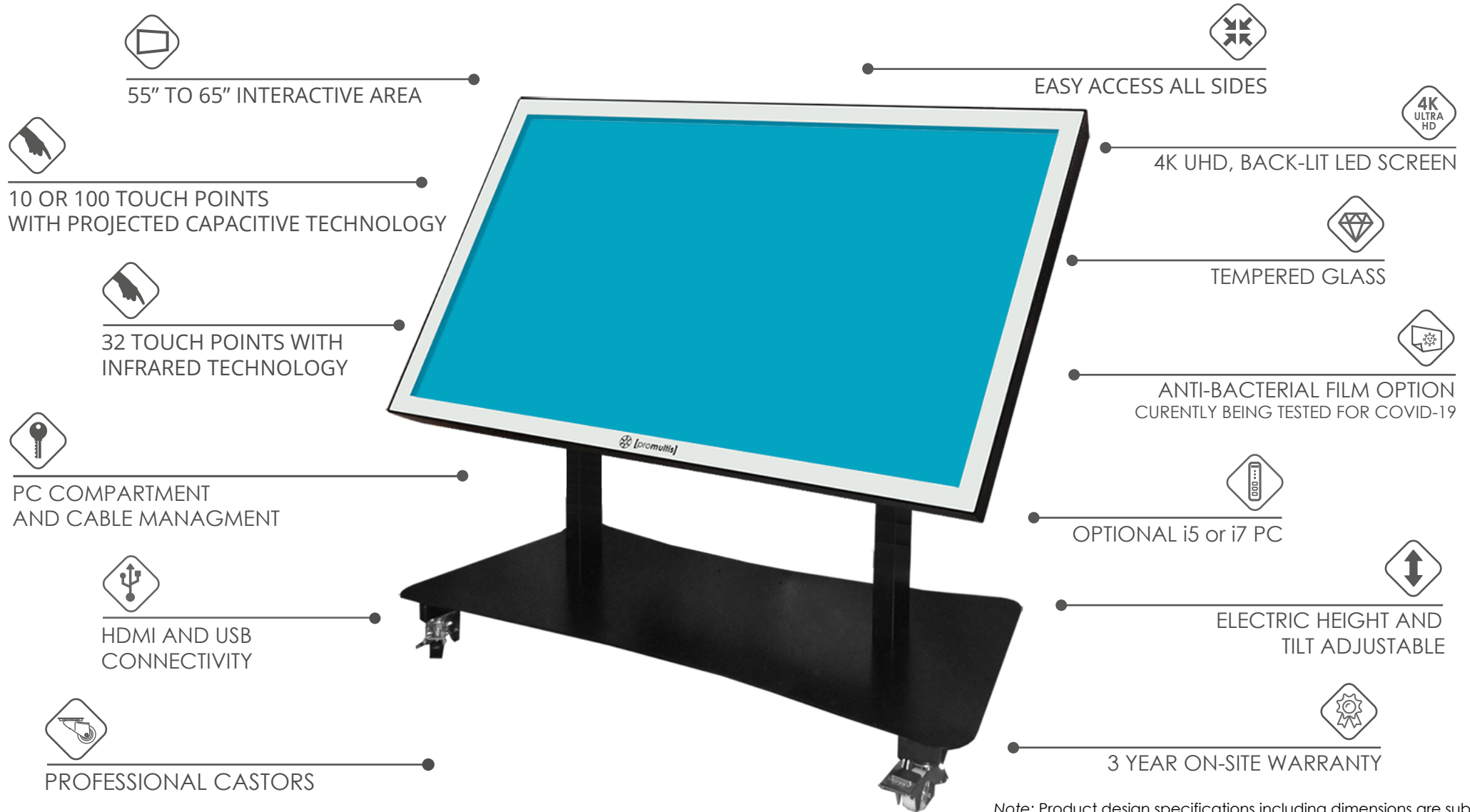

[promultis]

Varitilt Pro Mobile Table

Large electric height adjustable collaborative table with easy access from all sides. Ideal for Conference Rooms, Hospitality Suites, Training Areas and Trade Shows.



Note: Product design specifications including dimensions are subject to change without notice and may vary from those shown.

If you require an interactive, multitouch screen that is both mobile and has an easy to use configuration of screen height and angle then the Promultis Varitilt Pro is the solution.

The Promultis Varitilt Pro is one of our most versatile products and is available in a variety of screen sizes from 43" all the way up to 65" with the choice of 1080p HD or 4K UHD resolution. Utilising either Projected Capacitive or Infra-red touch technology. The real selling point with this range however, is it's flexibility and mobility!

The Promultis Varitilt Pro has height and tilt adjustment, the height elevation is adjusted by two powered columns to provide stability and finite adjustment. This allows the platform to be lifted, or lowered, effortlessly at the touch of a remote control. The Varitilt Pro also features fully powered tilt adjust. With its floor levelling castors, the Promultis Vari Tilt products can also be moved easily from room to room, much more convenient than a traditional wall mounted screen.

The mobility and adaptability afforded to the Varitilt really does set it apart from the competition. The fact that this product can be used as a very low table (improving accessibility for children and wheelchair users) or used as a high standing desk, or even tilted as a fully upright display or kiosk, means the Varitilt can be utilised in a wide variety of applications. The portability and flexibility of the Varitilt range has proven very popular in the education, SEN (Special Educational Needs), and the training market sectors.

Varitilt with Promultis Lightning Screen

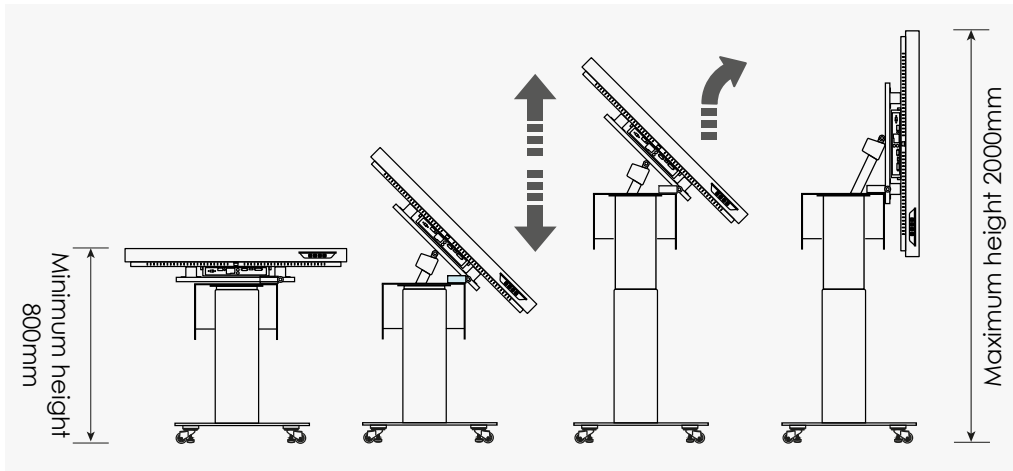

The flexible solution

The ability to adapt the height and the angle of the unit depending on the room, the light and the number of people viewing the screen is unsurpassed by any other product. The ease of which the unit can be moved between rooms also makes the Varitilt very well suited to large establishments that require the flexibility of multi-room use.



Complete Hardware & Software Solution from Promultis

Promultis can completely customise the unit with your branding while also providing interactive, touch software and digital signage solutions to meet your presentation and education needs.

Optional Bespoke Interactive Software

Engage with customers through a fully branded, interactive application with multi-user, collaborative interface incorporating your corporate identity, images, literature, audio files, videos, web sites and social media.

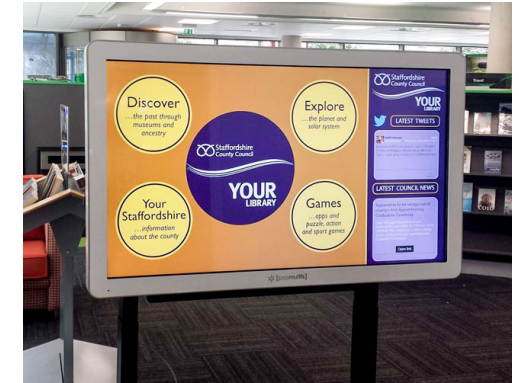

Promultis was commissioned to create an interactive presentation to be displayed on a 65" Varitilt Pro and other touch products.

Optional Software options

The Snowflake Suite Ultimate is perfect for education and training, its fully featured with all over 52 apps, including presentation, creativity and productivity tools, as well as games. It is intuitive and easy to use and customisable to suit your needs.



Promultis installed two 55" Varitilt tables for the National Library of Wales.

CHASSIS FEATURES	
Materials	Aluminum
Glass type	Toughened
Tray	Cable Mangement and PC shelf
Mobility	4 Professional Floor Levelling Castors
PANEL	
Interactive area	43" 55" 65"
Panel resolution	1080p HD or 4K UHD
Native resolution	1920 x 1080 or 3840 x 2160 60Hz
Brightness (nits)	450
Contrast ratio	1500 to 1
Response time	6ms
Aspect ratio	16x9
Viewing angle	178° / 178°
Pixel pitch	0.744 (mm)
LCD Illumination	Backlit LED
Speaker	10W x2
ENVIRONMENT	
Operating temperature	50°F to 104°F (10°C to 40°C)
Operating Humidity	10% to 80%, non-condensing
Storage Temperature	-4°F to 113°F (-20°C to 45°C)
Storage Humidity	5% to 95%, non-condensing
SHIPPED WITH	
Cables	Power USB HDMI
Remote control	Included
User manual	Included
WARRANTY	
3 year on-site warranty as standard	
Extended warranties and SLA's available at an additional cost	

INFRA RED TOUCH	
Touch Points	32
Touch sensitive to	Finger, Opaque object, Stylus
Sunlight Sensitivity	Can be used in direct sunlight
Interpolation	32,768x32,768
Response time	Repeated touch <6ms
Drift	None
Temperature	-20°C~60°C
Accuracy	±2mm
Interface	USB-2
Relative Humidity	10%~90%RH
Supported	OS Windows, MAC, Linux, Android
PROJECTED CAPACITIVE	
Detection method	Projected Capacitive
Input method	Finger and gloved finger
Number of simultaneous touches	10 or 100
Noise Shielding	DISPLAX XTR-Shield™ Plus, a proprietary noise filtering technology
Aspect ratio	16:9
Controller	Printed circuit board with mini USB connector
Adhesive	Permanent
Interface	HID
OS with multitouch	Windows 8.1, 8, 7, 10; Ubuntu 12.04; Android; Chrome OS
OS with single touch	Mac OS X Yosemite
OS with mouse emulation	Spinetix Media Player HMP 200
Data connectivity	USB 2.0
Touch accuracy	1mm absolute

PERFORMANCE	
Substrate thickness	Up to 6mm
Touch response	5 milliseconds
Calibration	Available using control panel: no drift
POWER CONSUMPTION	
Average power consumption (P)	USB powered @ 5V
	Peak consumption: 410 mA
	Operation consumption: 370mA
RELIABILITY	
Operating temperature range	-20°C to 70°C
Operating humidity range	0% to 96%
Life time expectancy	Unlimited
Controller life time expectancy	1 million hours



[promultis]

Vari Tilt Pro with 55" interactive area

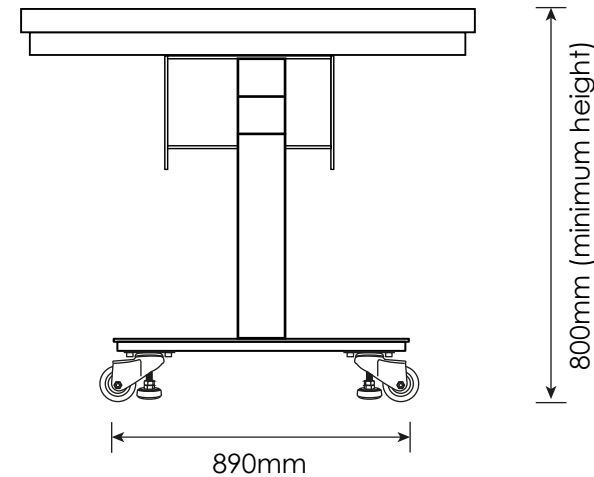
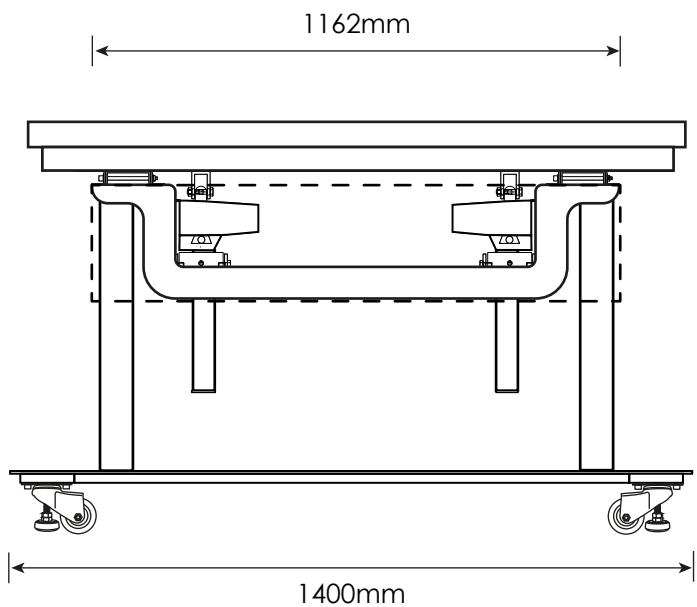
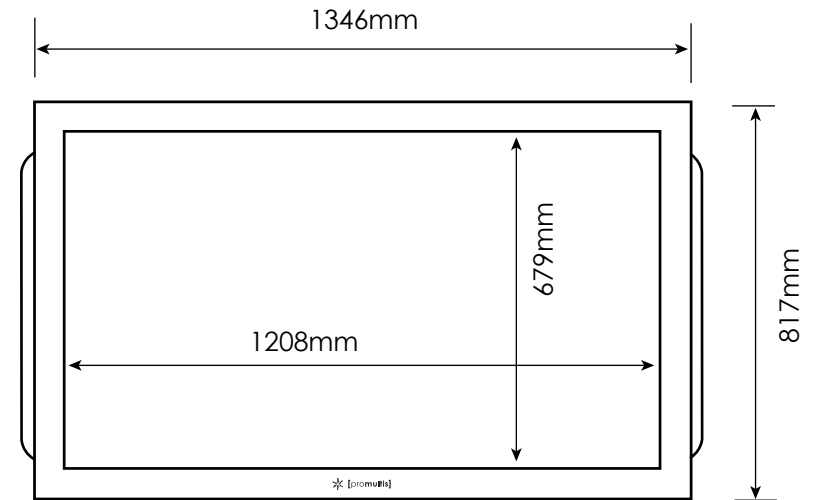
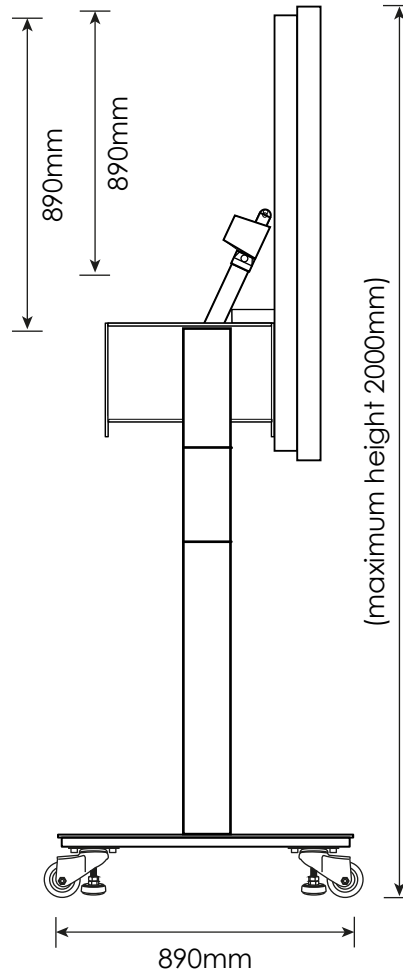
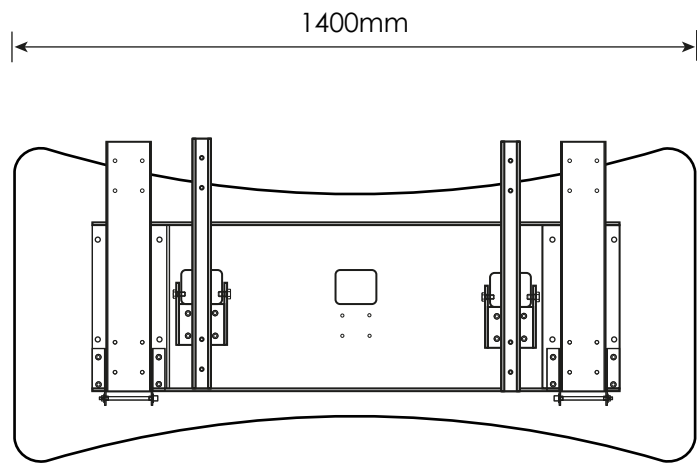



[promultis]

Vari Tilt Pro with 65" interactive area

