



[promultis]

# Standard Kiosk

Create an inviting and immersive information point with this Kiosk.  
Ideal for digital signage and wayfinding solutions.



20, 40 OR 100 TOUCH POINTS  
WITH PROJECTED CAPACITIVE  
TECHNOLOGY



OBJECT RECOGNITION  
READY OPTION



i7 NUC PC



HDMI AND USB CONNECTIVITY



49", 55", 65" & 85" 4K UHD  
BACK-LIT LED SCREEN



32 TOUCH POINTS  
WITH INFRARED



ANTI-BACTERIAL  
FILM OPTION  
CURRENTLY BEING TESTED  
FOR COVID-19



SECURE PC COMPARTMENT  
AND CABLE MANAGEMENT



3 YEAR ON-SITE WARRANTY

Note: Product design specifications including dimensions are subject to change without notice and may vary from those shown.



[promultis]  
MULTITOUCH SOLUTIONS



Made in Britain

For more exciting multitouch products visit  
[www.promultis.info](http://www.promultis.info)  
or call +44 (0) 239 251 2794

**The Promultis standard kiosk has been designed for indoor use and is an ideal way to engage your audience with content that can inform, attract, entertain and educate.**

The Promultis Kiosk is available in a variety of configurations that can suit any budget and any situation! Constructed with only the highest-grade components, our commercial LED screens are available with 1080p or 4K resolution and up to 800 nit high brightness.

Making the Promultis Kiosk perfect for use in areas with excessive light such as foyers and exhibition halls. You have the option of 49", 55", 65" or 85" screens and also a choice between the very latest Infrared technology which allows up to 32 touches or Projected Capacitive touch technology which allows for 20, 40 or 100 touch points and a completely flat surface.



Promultis Standard Kiosk is ideal for

- Retail Environments
- Exhibitions & Events
- Corporate Spaces
- Hospitality
- Transportation
- Entertainment



#### **Lockable storage and cable management**

The Promultis has a discreet, lockable cabinet with two shelves to house a PC and effective cable management.

#### **Colour and applied graphics**

The Promultis standard kiosk is available in a variety of colours. Select a colour for the screen bezel and add your logo. In addition, the device can be vinyl wrapped with graphics to reflect your branding or campaign messages.



#### **Immerse Bespoke Interactive Software from Promultis**

Promultis offers a bespoke software creation service where our software development team will create a multitouch interactive experience to run on your touch table. Visit our website at <https://immerse.promultis.info/> for example applications and case studies.



#### **Software options**

The Snowflake Suite Ultimate is perfect for education and training, its fully featured with all over 52 apps, including presentation, creativity and productivity tools, as well as games. It is intuitive and easy to use and customisable to suit your needs.

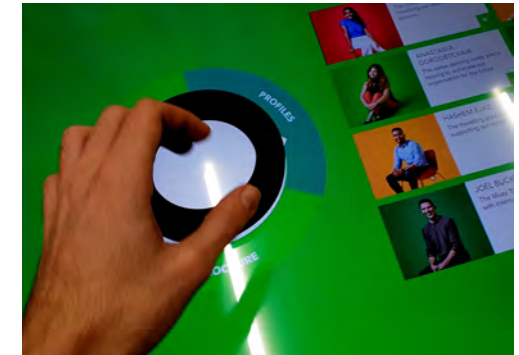

#### **Object Recognition Ready**

Object recognition is the ability to drop an interactive puck onto the screen and the screen to react to that object and display relevant content such as videos, pictures and graphics. Promultis offers an object recognition software service detailed on the Immerse website.

CHASSIS FEATURES	
Materials	Aluminium & Steel
Glass type	Toughened full transmittivity
Lockable Storage	Cable Management and PC shelf
PANEL	
Screen Options	49"   55"   65"   85"
Panel resolution	1080p HD OR 4K UHD
Native resolution	3840 x 2160 60Hz
Brightness (nits)	450
Contrast ratio	1500 to 1
Response time	6ms
Aspect ratio	16x9
Viewing angle	178° / 178°
Pixel pitch	0.744 (mm)
LCD Illumination	Backlit LED
Speaker	10W x2
ENVIRONMENT	
Operating temperature	50°F to 104°F (10°C to 40°C)
Operating Humidity	10% to 80%, non-condensing
Storage Temperature	-4°F to 113°F (-20°C to 45°C)
Storage Humidity	5% to 95%, non-condensing
SHIPPED WITH	
Cables	Power   USB   HDMI
Remote control	Included
Screen freeze function	On remote control
User manual	Included
WARRANTY	
3 year on-site warranty as standard	
Extended warranties and SLA's available at an additional cost	

INFRA RED TOUCH	
Touch Points	10 or 32
Touch sensitive to	Finger, Opaque object, Stylus
Sunlight Sensitivity	Can be used in direct sunlight
Interpolation	32,768x32,768
Response time	Repeated touch <6ms
Drift	None
Temperature	-20°C~60°C
Accuracy	±2mm
Interface	USB-2
Relative Humidity	10%~90%RH
Supported	OS Windows, MAC, Linux, Android
PROJECTED CAPACITIVE	
Detection method	Projected Capacitive
Input method	Finger and gloved finger
Number of simultaneous touches	20. 40 or 100
Noise Shielding	DISPLAX XTR-Shield™ Plus, a proprietary noise filtering technology
Aspect ratio	16:9
Controller	Printed circuit board with mini USB connector
Adhesive	Permanent
Interface	HID
OS with multi-touch	Windows 8.1, 8, 7*: Ubuntu 12.04**; Android**; Chrome OS***
OS with single touch	Mac OS X Yosemite
OS with mouse emulation	Spinetix Media Player HMP 200

\* Home Premium SP1; Professional SP1 Ultimate x64 SP1 \*\* Depending on kernel and multi-touch support. \*\*\* 390.2171.85(64 bit)

Data connectivity	USB 2.0
Touch accuracy	1mm absolute
Sensor weight	260 g
Controller weight	60 g
PERFORMANCE	
Substrate thickness	Up to 6mm
Touch response	5 milliseconds
Calibration	Available using control panel: no drift
POWER CONSUMPTION	
	USB powered @ 5V
Average power consumption (P)	Peak consumption: 410 mA Operation consumption: 370mA
RELIABILITY	
Operating temperature range	-20°C to 70°C
Operating humidity range	0% to 96%
Life time expectancy	Unlimited
Controller life time expectancy	1 million hours

Note: Product design specifications including dimensions are subject to change without notice and may vary from those shown.



[promultis]

# Standard Kiosk with 85" Boxtop touch screen

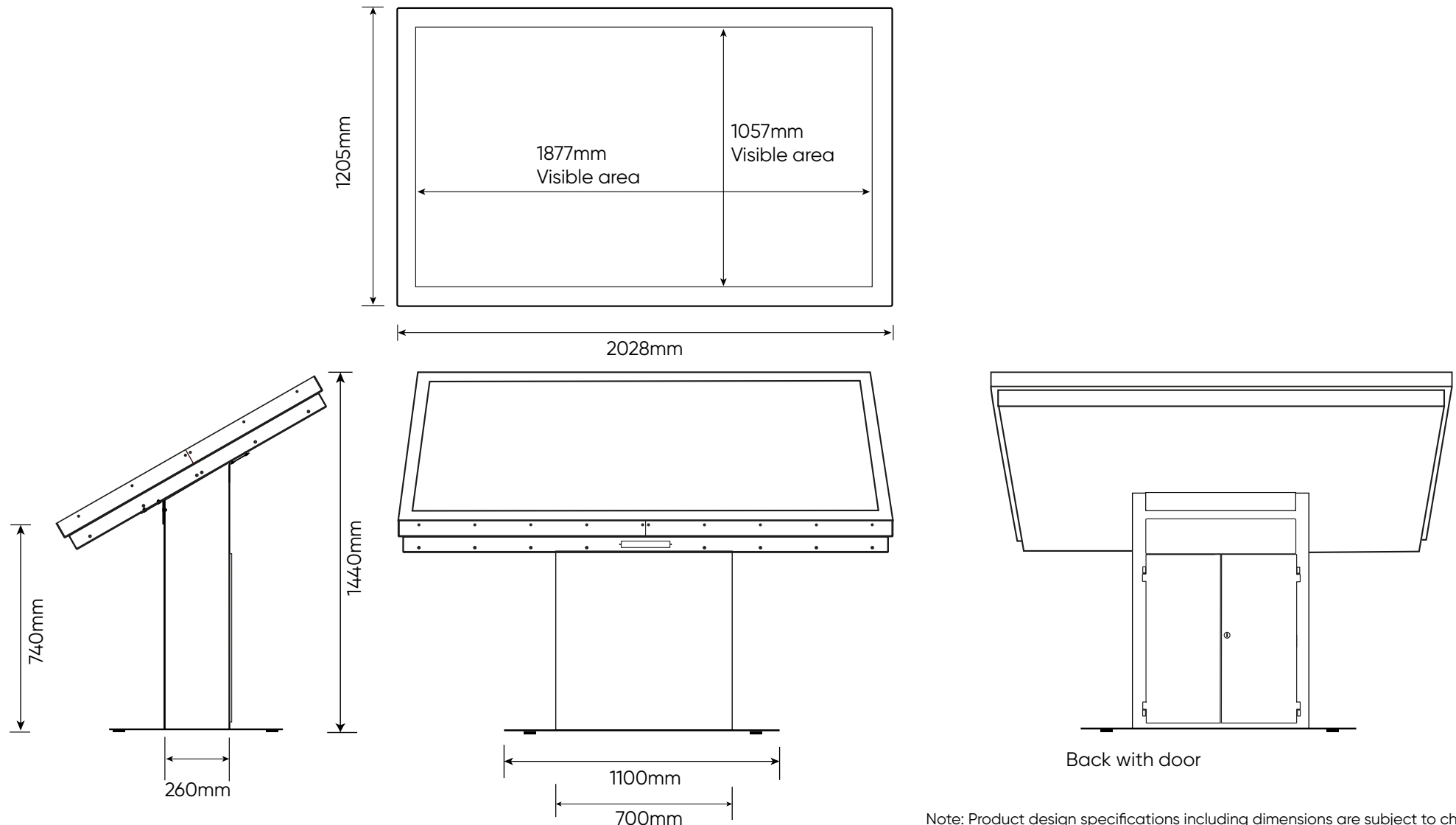

Note: Product design specifications including dimensions are subject to change without notice and may vary from those shown.



[promultis]

# Standard Kiosk with 65" Boxtop touch screen

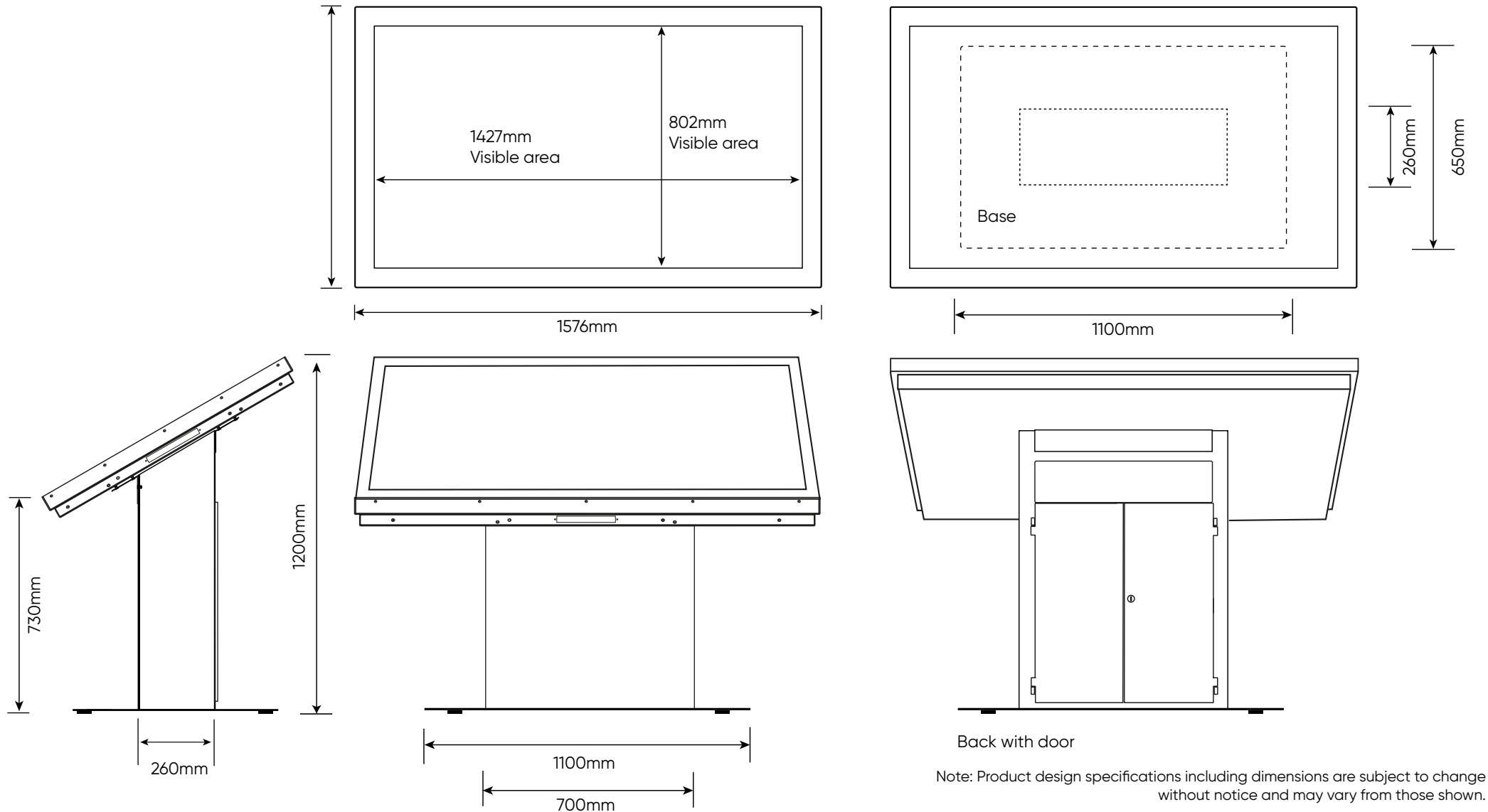



[promultis]

# Standard Kiosk with 55" Boxtop touch screen

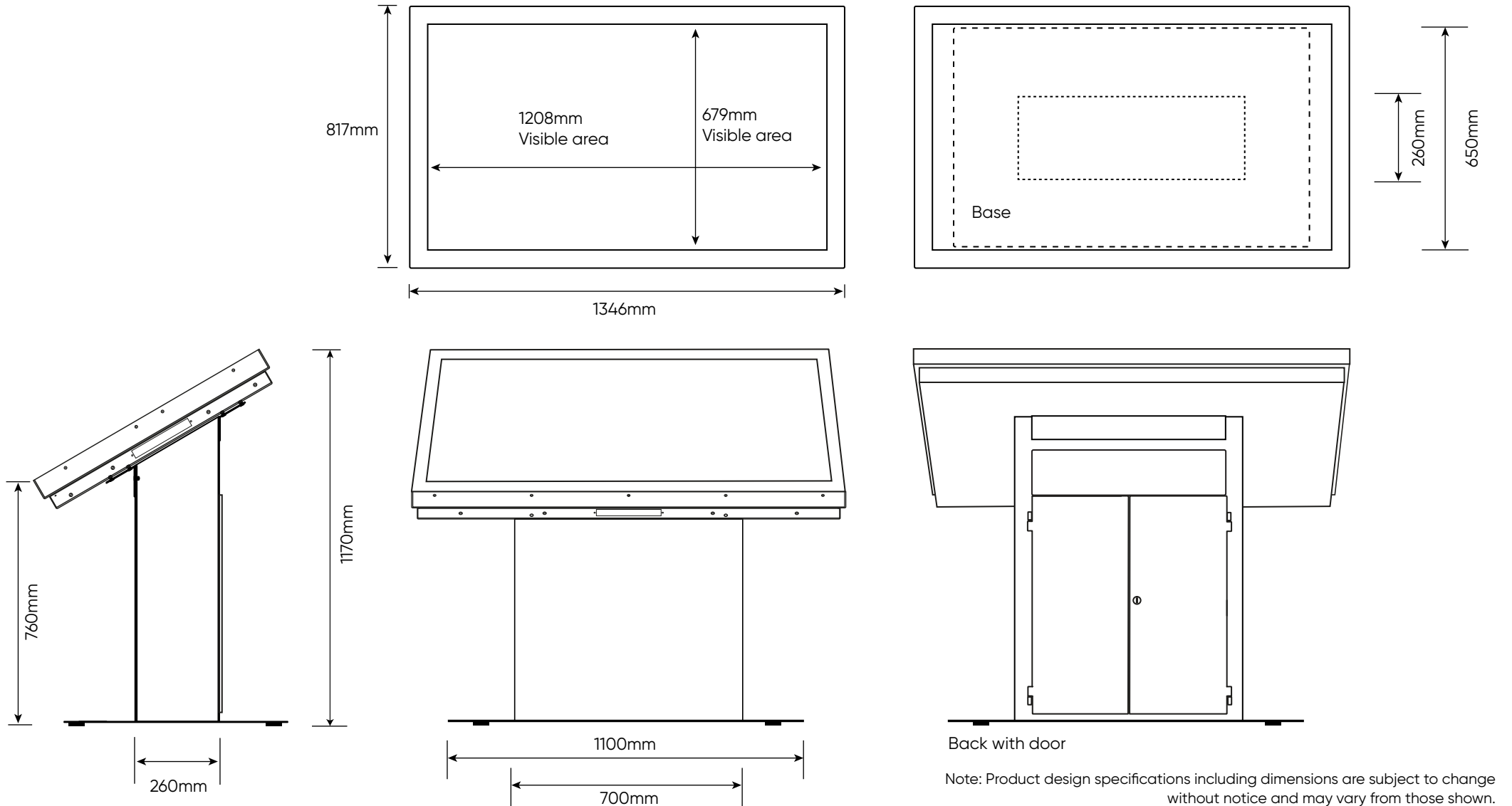



[promultis]

# Standard Kiosk with 49" Boxtop touch screen

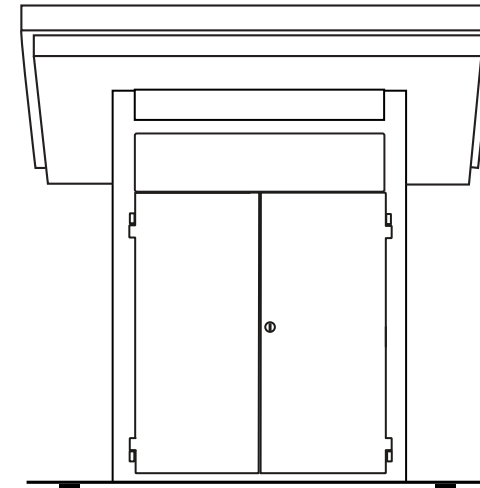
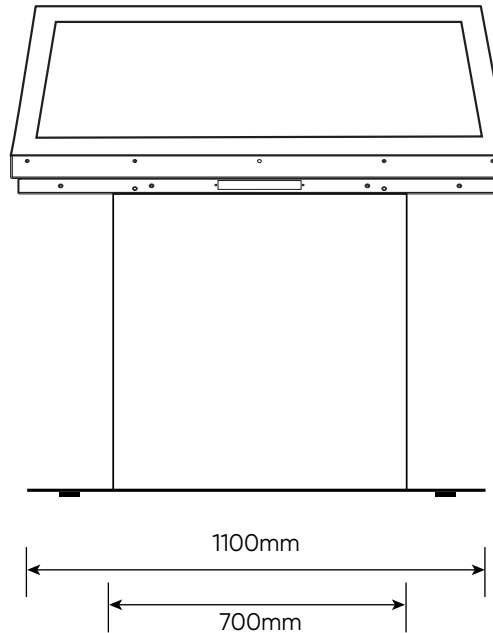
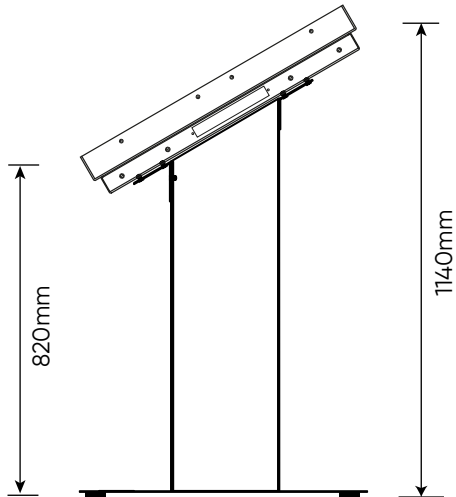
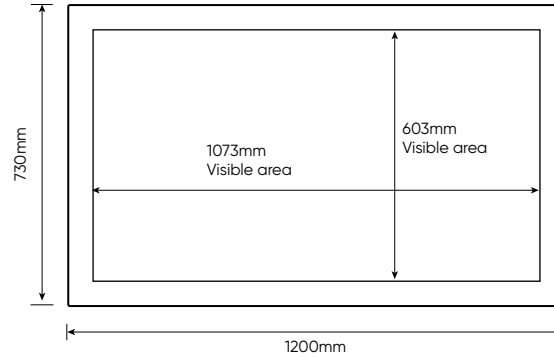

Back with door

Note: Product design specifications including dimensions are subject to change without notice and may vary from those shown.



[promultis]  
MULTITOUCH SOLUTIONS

For more exciting multitouch products visit  
[www.promultis.info](http://www.promultis.info)  
or call +44 (0) 239 251 2794