



[promultis]

Varitilt Elite Mobile Interactive Table

Large electric height and tilt adjustable mobile table with robust interactive touch screen.
Ideal for Schools, Colleges, Universities, Hospitality Suites, Training Areas and Trade Shows.



Note: Product design specifications including dimensions are subject to change without notice and may vary from those shown.



The Varitilt Elite also features fully powered tilt adjust. With its floor levelling castors, the Promultis Varitilt products can also be moved easily from room to room.



This product can be used as a very low table (improving accessibility for children and wheelchair users) or used as a high standing desk, or even tilted as a fully upright display or kiosk, means the Varitilt can be utilised in a wide variety of applications. The portability and flexibility of the Varitilt range has proven very popular in the education, SEN (Special Educational Needs), and the training market sectors.



If you require an interactive, multitouch screen that is both mobile and has an easy to use configuration of screen height and angle then the Promultis Varitilt Elite is the solution.

The Promultis Varitilt Elite is one of our most versatile products and is available in a variety of screen sizes from 65" all the way up to 86". Utilising either Projected Capacitive or Infra-red touch technology with the 4K UHD screen. The real selling point with this range however, is its flexibility and mobility!

The Promultis Varitilt Elite has height and tilt adjustment, the height elevation is adjusted by two powered columns to provide stability and finite adjustment. This allows the platform to be lifted, or lowered, effortlessly at the touch of a remote control.



Colour bezel, graphics and logos

Select a colour for your bezel and add a corporate logo and apply graphics.



Immerse Bespoke Interactive Software from Promultis

Promultis offers a bespoke software creation service where our software development team will create a multitouch interactive experience to run on your touch table. Visit our website at <https://immerse.promultis.info/> for example applications and case studies.

Software options

The Snowflake Suite Ultimate is perfect for education and training, its fully featured with over 52 apps, including presentation, creativity and productivity tools, as well as games. It is intuitive and easy to use and customisable to suit your needs.



Object Recognition Ready

Object recognition is the ability to drop an interactive puck onto the screen and the screen to react to that object and display relevant content such as videos, pictures and graphics. Promultis offers an object recognition software service detailed on the Immerse website.



CHASSIS FEATURES	
Materials	Aluminium
Glass type	Toughened
Tray	Cable Management and PC shelf
Mobility	4 Professional Floor Levelling Castors
PANEL	
Interactive area	65" 75" 86"
Panel resolution	4K UHD 3840 x 2160
Native resolution	3840 x 2160 60Hz
Brightness (nits)	450
Contrast ratio	1500 to 1
Response time	6ms
Aspect ratio	16x9
Viewing angle	178° / 178°
Pixel pitch	0.744 (mm)
LCD Illumination	Backlit LED
Speaker	10W x2
ENVIRONMENT	
Operating temperature	50°F to 104°F (10°C to 40°C)
Operating Humidity	10% to 80%, non-condensing
Storage Temperature	-4°F to 113°F (-20°C to 45°C)
Storage Humidity	5% to 95%, non-condensing
SHIPPED WITH	
Cables	Power USB HDMI
Remote control	Included
User manual	Included
WARRANTY	
3 year on-site warranty as standard	
Extended warranties and SLA's available at an additional cost	

INFRA RED TOUCH	
Touch Points	32
Touch sensitive to	Finger, Opaque object, Stylus
Sunlight Sensitivity	Can be used in direct sunlight
Interpolation	32,768x32,768
Response time	Repeated touch <6ms
Drift	None
Temperature	-20°C~60°C
Accuracy	±2mm
Interface	USB-2
Relative Humidity	10%~90%RH
Supported	OS Windows, MAC, Linux, Android
PROJECTED CAPACITIVE	
Detection method	Projected Capacitive
Input method	Finger and gloved finger
Number of simultaneous touches	40 / 100
Noise Shielding	DISPLAX XTR-Shield™ Plus, a proprietary noise filtering technology
Aspect ratio	16:9
Controller	Printed circuit board with mini USB connector
Adhesive	Permanent
Interface	HID
OS with multitouch	Windows 8.1, 8, 7, 10; Ubuntu 12.04; Android; Chrome OS
OS with single touch	Mac OS X Yosemite
OS with mouse emulation	Spinetix Media Player HMP 200
Data connectivity	USB 2.0
Touch accuracy	1mm absolute

PERFORMANCE	
Substrate thickness	Up to 6mm
Touch response	5 milliseconds
Calibration	Available using control panel: no drift
POWER CONSUMPTION	
Average power consumption (P)	USB powered @ 5V
	Peak consumption: 410 mA
	Operation consumption: 370mA
RELIABILITY	
Operating temperature range	-20°C to 70°C
Operating humidity range	0% to 96%
Life time expectancy	Unlimited
Controller life time expectancy	1 million hours



[promultis]

Varitilt Elite with 85" Projected Capacitive Touch screen

Note: Product design specifications including dimensions are subject to change without notice and may vary from those shown.

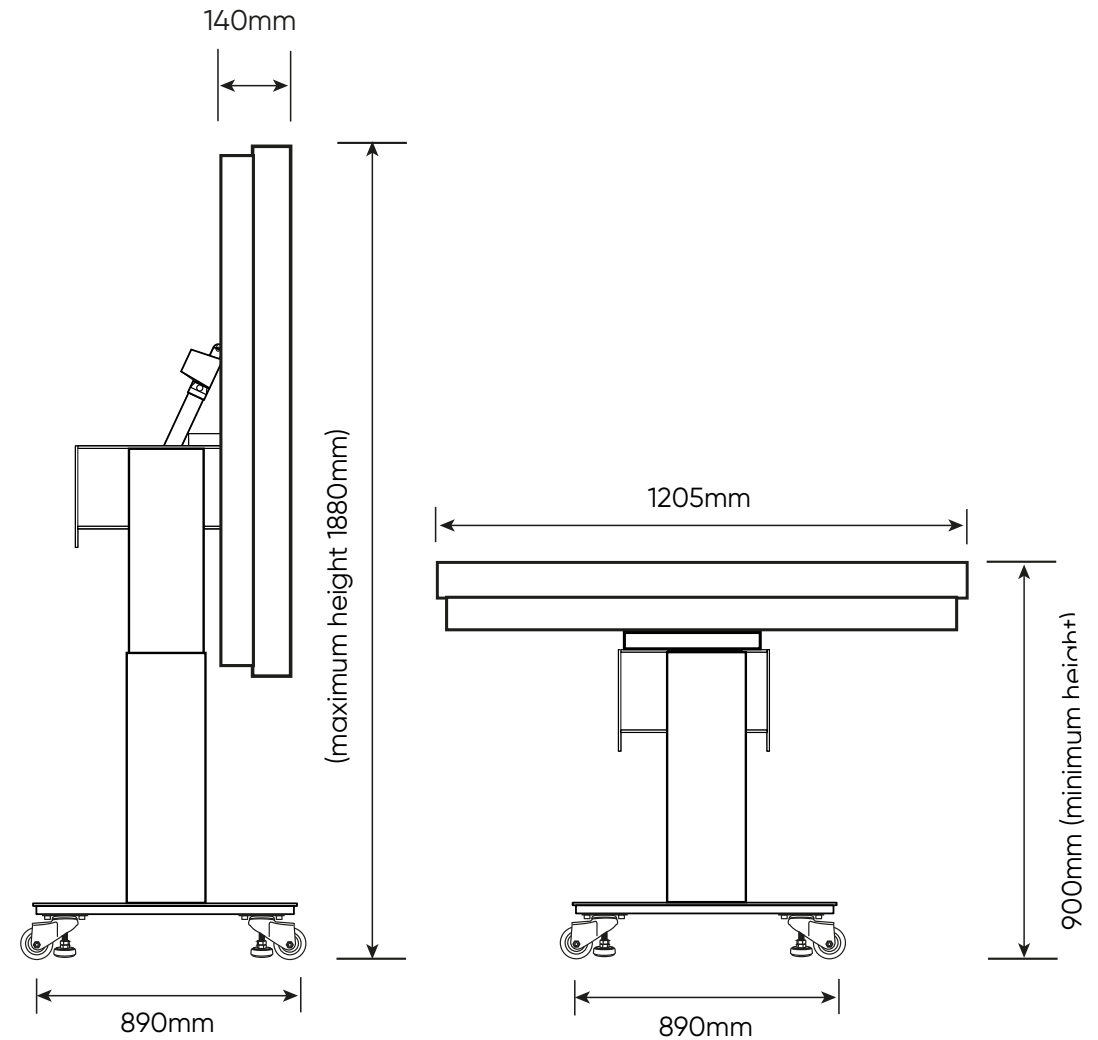
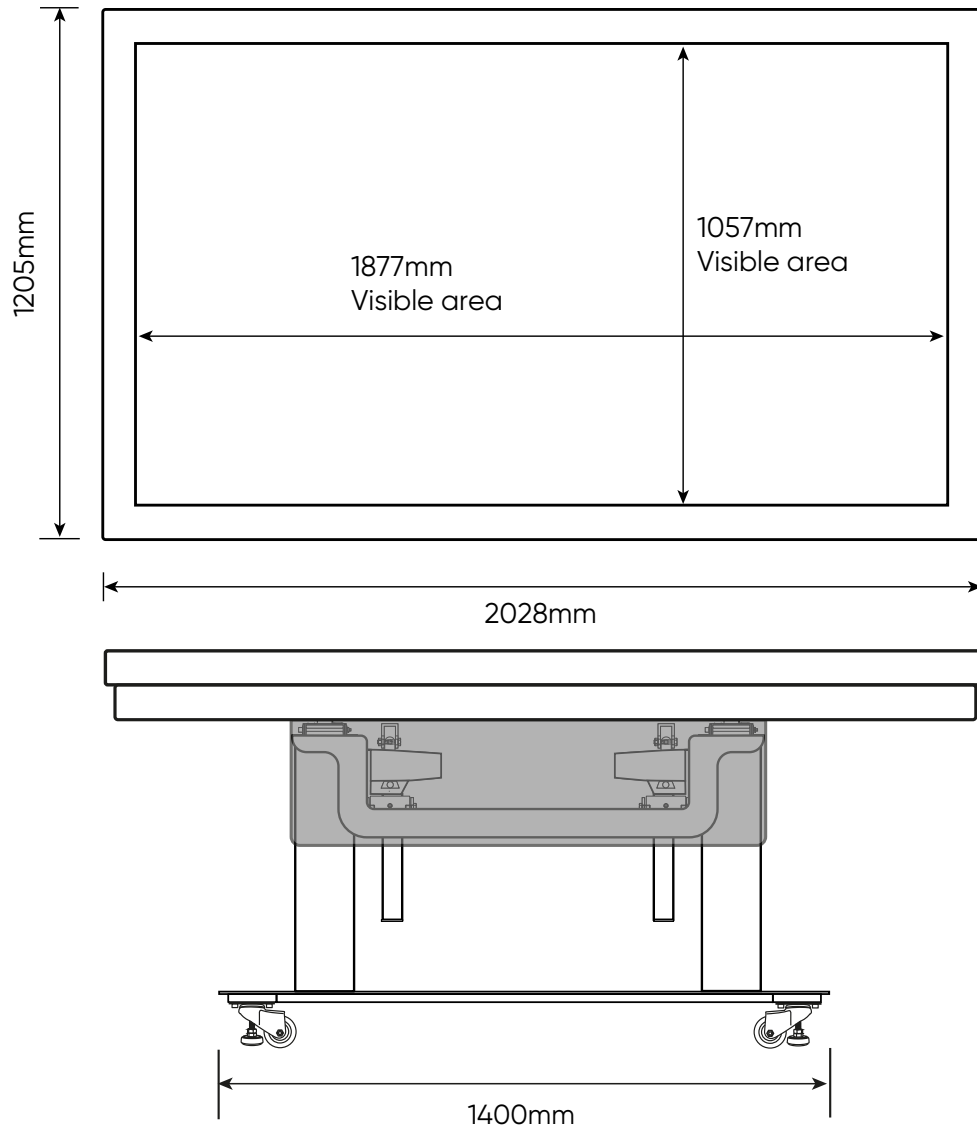



[promultis]

Varitilt Elite with 75" Projected Capacitive Touch screen

Note: Product design specifications including dimensions are subject to change without notice and may vary from those shown.

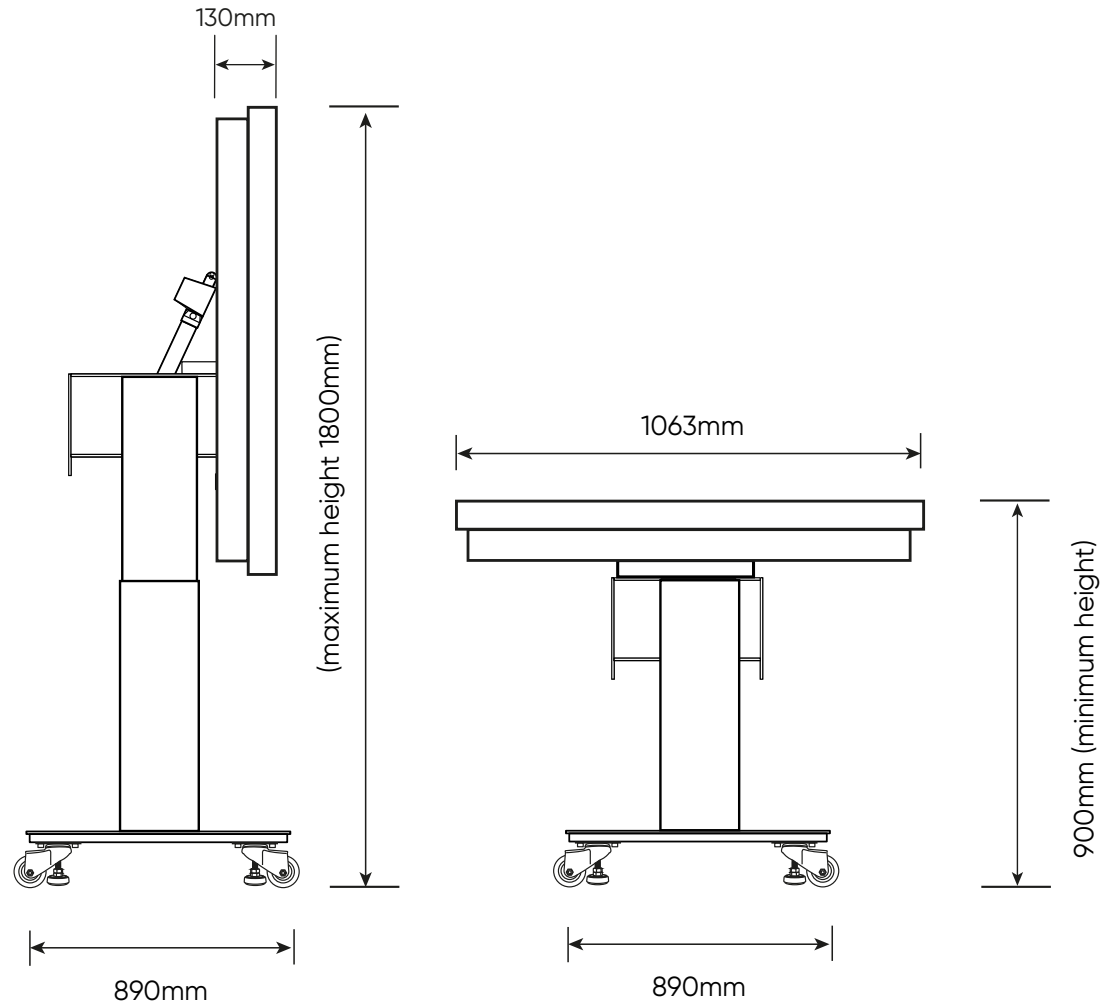
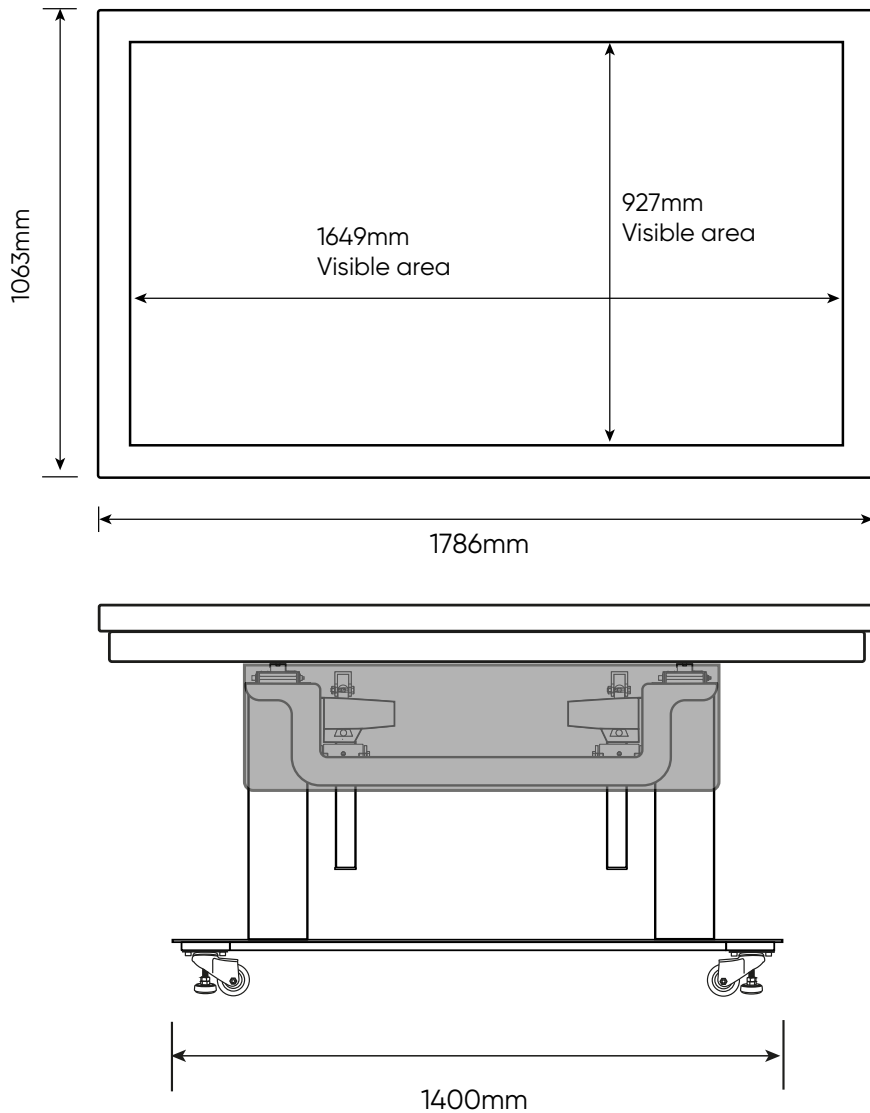



[promultis]

Varitilt Elite with 65" Projected Capacitive Touch Screen

Note: Product design specifications including dimensions are subject to change without notice and may vary from those shown.

