

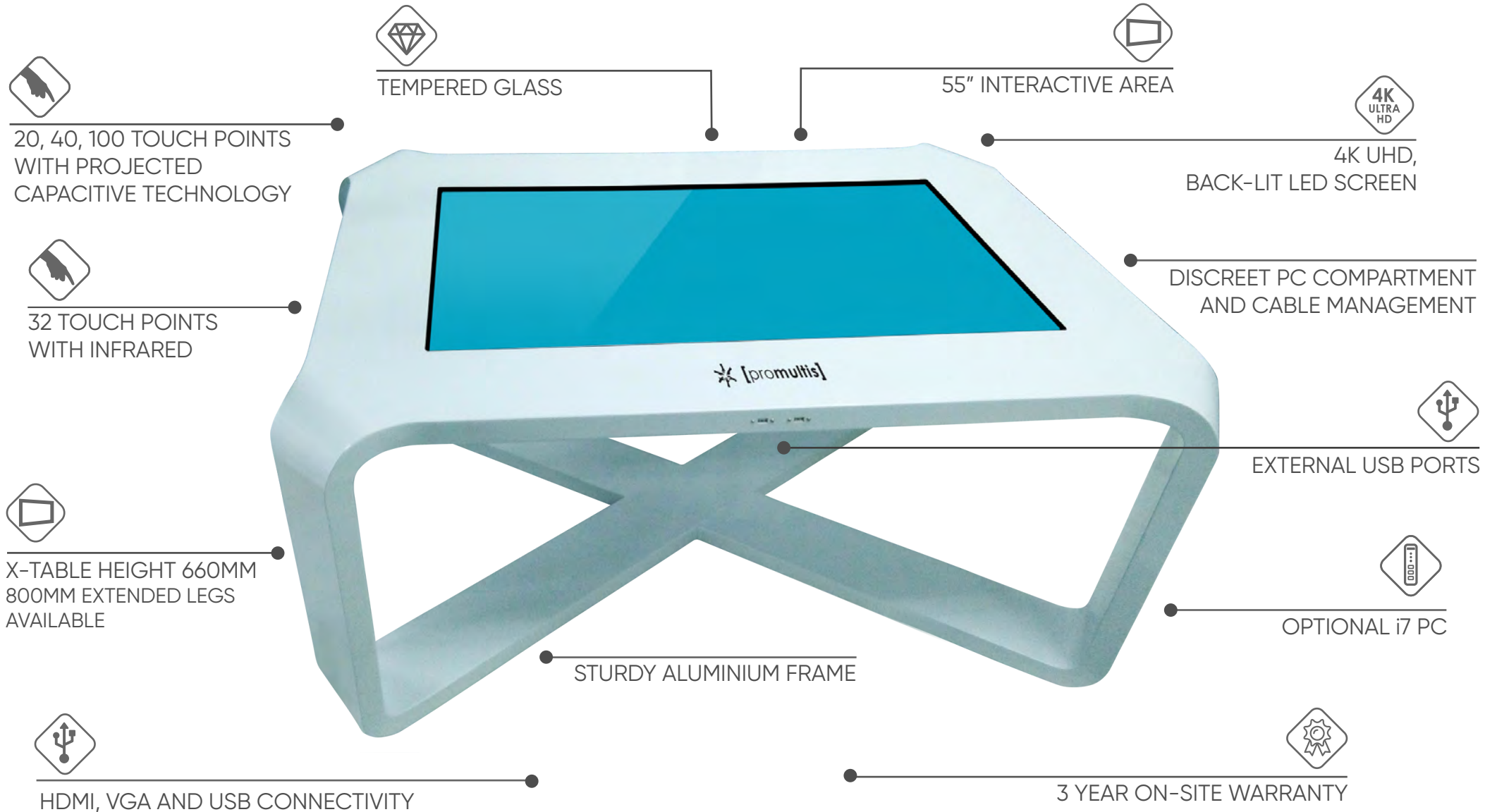

[promultis]

Touch X-table

The Promultis X-table is a complete multi touch, collaborative interactive surface solution that integrates the latest touch screen technology into a stunning looking table.



The Promultis Table is a slim, stylish and futuristic piece of hardware. Constructed from sturdy aluminium in a coffee table design, the Promultis Table is a collaborative, interactive multitouch surface solution that integrates the latest touch screen technology into a user-friendly and intuitive design.

The Promultis Table is available in a variety of configurations; Interactive areas from 42" up to 65", the choice of 1080p HD or 4K UHD LED screens, optional integrated PC and a choice of software bundles. There is also the option of infra-red or capacitive touch technology with up to 32 touch points, and custom leg height options that make the table optimal for wheel chair users.

When configured with capacitive touch technology, the table top can have an almost completely flat surface, also, with discreet power outlets and efficient, safe cable management, the Promultis Table is incredibly tidy and minimal in appearance.

Promultis touch tables are ideal for:

- Receptions
- Foyer Areas
- Waiting Rooms
- Dining Halls
- Coffee Areas
- Exhibition Stands
- Libraries

Secure PC housing

Should an integrated PC be specified, there is a secure PC housing beneath the table.



Integrated USB connections

Includes 4 USB ports accessible from the sides of the table.

Table dimensions

	Width	Depth	Height
42"	800 mm	1600 mm	650 mm*
48"	800 mm	1600 mm	650 mm*
55"	1000 mm	2000 mm	650 mm*
65"	1000 mm	2000 mm	650 mm*



**800mm taller leg option available at additional cost*



The table provides a large working surface area allowing several users to collaborate all at the same time. Users can control the content they see by using natural gestures such as pinch, zoom and drag.



The Promultis Table allows your business to engage, inform and entertain customers in a host of ways. The Promultis Table can also allow you to gain valuable insight into your customers, making the Promultis Table a highly effective data collection tool! It can also be branded with your own identity or promotion.



Software options

The Snowflake Suite Ultimate is perfect for education and training, its fully featured with all over 52 apps, including presentation, creativity and productivity tools, as well as games. It is intuitive and easy to use and customisable to suit your needs.



Bespoke Interactive Software

Engage with customers through a fully branded, interactive application with multi-user, collaborative interface incorporating your corporate identity, images, literature, audio files, videos, web sites and social media.



CHASSIS FEATURES	
Materials	Aluminum
Glass type	Toughened
Enclosure	PC and Cable Mangement
Base	4 Floor Levelling Castors
PANEL	
Interactive area	55"
Panel resolution	4K UHD
Native resolution	3840 x 2160
Brightness (nits)	450
Contrast ratio	1500 to 1
Response time	6ms
Aspect ratio	16x9
Viewing angle	178° / 178°
Pixel pitch	0.744 (mm)
LCD Illumination	Backlit LED
Speaker	10W x2
ENVIRONMENT	
Operating temperature	50°F to 104°F (10°C to 40°C)
Operating Humidity	10% to 80%, non-condensing
Storage Temperature	-4°F to 113°F (-20°C to 45°C)
Storage Humidity	5% to 95%, non-condensing
SHIPPED WITH	
Cables	Power USB HDMI
Remote control	Included
User manual	Included
WARRANTY	
3 year on-site warranty as standard	
Extended warranties and SLA's available at an additional cost	

INFRA RED TOUCH	
Touch Points	32
Touch sensitive to	Finger, Opaque object, Stylus
Sunlight Sensitivity	Can be used in direct sunlight
Interpolation	32,768x32,768
Response time	Repeated touch <6ms
Drift	None
Temperature	-20°C~60°C
Accuracy	±2mm
Interface	USB-2
Relative Humidity	10%~90%RH
Supported	OS Windows, MAC, Linux, Android
PROJECTED CAPACITIVE	
Detection method	Projected Capacitive
Input method	Finger and gloved finger
Number of simultaneous touches	20, 40, 100
Noise Shielding	DISPLAX XTR-Shield™ Plus, a proprietary noise filtering technology
Aspect ratio	16:9
Controller	Printed circuit board with mini USB connector
Adhesive	Permanent
Interface	HID
OS with multitouch	Windows 8.1, 8, 7, 10; Ubuntu 12.04; Android; Chrome OS
OS with single touch	Mac OS X Yosemite
OS with mouse emulation	Spinetix Media Player HMP 200
Data connectivity	USB 2.0
Touch accuracy	1mm absolute

PERFORMANCE	
Substrate thickness	Up to 6mm
Touch response	5 milliseconds
Calibration	Available using control panel: no drift
POWER CONSUMPTION	
Average power consumption (P)	USB powered @ 5V
	Peak consumption: 410 mA
	Operation consumption: 370mA
RELIABILITY	
Operating temperature range	-20°C to 70°C
Operating humidity range	0% to 96%
Life time expectancy	Unlimited
Controller life time expectancy	1 million hours



[promultis]

55" Touch X-table

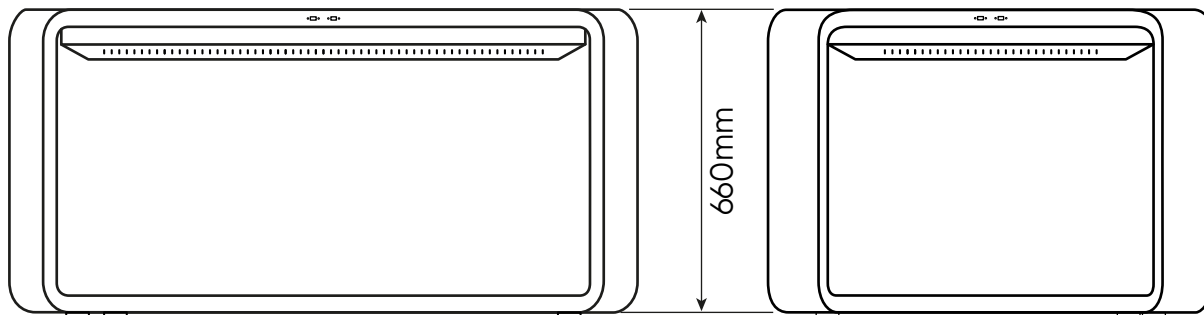
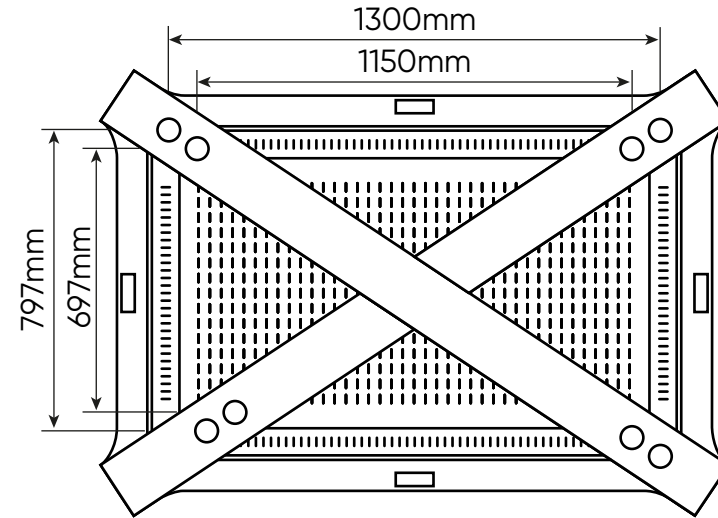
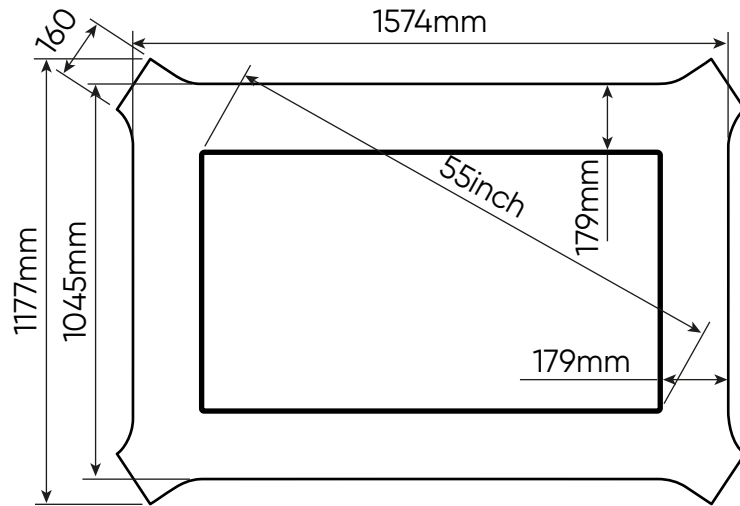

[promultis]
MULTITOUCH SOLUTIONS

For more exciting multitouch products visit
www.promultis.info
or call +44 (0) 239 251 2794



[promultis]

55" Touch X-table with extended legs

